

INSTALLATION, OPERATING AND MAINTENANCE INSTRUCTIONS FOR FAIRCHILD MODEL 16 VACUUM REGULATOR

GENERAL INFORMATION

The Model 16 Vacuum regulator offers in a single unit the ability to control system pressure whether the setpoint is below or above atmosphere pressure.

Specifications

Model 16

Flow capacity2.5 SCFM @ 29" Hg Vac.

Sensitivity $\frac{1}{2}$ " W.C.
 Effect of Supply Less than 0.1 psi [.007 BAR]
 pressure variation (.7 kPa) for 100 psi [7.0 BAR]
 (700 kPa) change
 Supply pressure 250 psi [17 BAR] (1700 kPa)
 Mounting pipe or panel
 Ambient Temperature Limits -40° F to +200° F
 (-40°C to +93.3°C)

PRINCIPLES OF OPERATION

In a conventional pressure regulator, supply pressure P_s is operated on by the control mechanism to cause a reduction to regulated pressure P_o . Fluid is vented to atmosphere in order to maintain the differential between P_s and P_o .

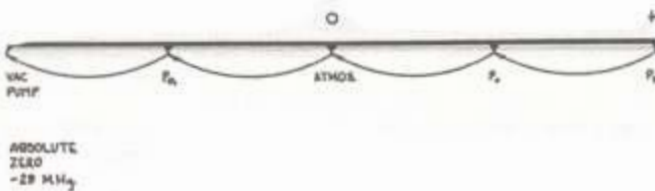

The vacuum regulator goes a step further in that atmospheric pressure is operated on by the control mechanism to cause a reduction to regulated pressure P_{o1} . Fluid is vented to a vacuum pump (29 inches mercury absolute) in order to maintain the differential pressure between atmospheric pressure and P_{o1} .

The Model 16 utilizes a balanced supply valve, but in addition it has a chamber A isolated from atmosphere, which contains a spring which opposes the conventional range spring. With supply pressure turned off and the control knob turned to allow the positive bias spring to be expanded, the supply valve and relief valve are seated because of the upward force of the supply valve spring.

When the supply air is introduced to the inlet port, it exerts pressure against the supply valve and at the same time exerts pressure against the inner valve assembly balance diaphragm. The two opposite acting forces tend to keep the supply valve assembly balanced and virtually unaffected by changes in supply pressure.

Where control of system pressure P_o above and below atmospheric pressure is required, the vacuum source would be attached to the additional chamber.

When the knob of the regulator is adjusted to a specific set point, the positive bias spring exerts a force against the top of the signal diaphragm. Air at atmospheric pressure enters through the bonnet vent and is present on the top of the signal diaphragm.

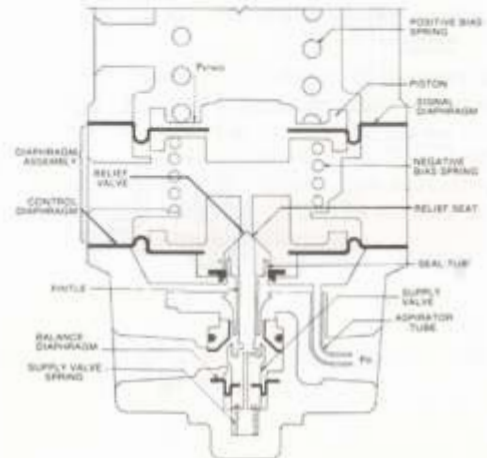

Figure 1A

The negative bias spring force acts against the bottom of the signal diaphragm. The combined force is the result of P_{atmos} acting downward on the signal diaphragm area plus the spring force minus the negative bias spring force and the supply valve spring force acting upward on the bottom of the signal diaphragm. The resulting output pressure P_o is $(K_1 + P_{atmos} \times Area - K_2) - P_o \times area$ where P_o is the output pressure, P_{atmos} is atmospheric pressure and K_1 and K_2 are spring constants. This force will keep the relief seat against the relief valve. This condition is not achieved until output pressure reaches the desired set point. Until then, the downward force opens the supply valve allowing supply air to be routed to the outlet port. Downstream (outlet) pressure is transmitted through the aspirator tube to the control chamber and sensed on the underside of the control diaphragm. The increase in pressure on the control diaphragm causes the diaphragm assembly to move upward sliding on the seal tube against the force of atmospheric pressure acting on the signal diaphragm and the positive bias spring force acting on the piston assisted by the negative bias spring force. This force acting through the pintle allows the supply valve to throttle, maintaining output pressure.

Downstream pressure is transmitted down through the channel in the supply valve to the underside of the inner valve assembly balance diaphragm. Downstream pressure also acts on the top of the supply valve.

When set point is reached, the forces acting on the top and bottom of the signal diaphragm are in balance with the forces acting on the bottom of the control diaphragm. At this point, the force (1) due to supply pressure acting on the supply valve is in balance with the force (1) due to pressure acting on the inner valve assembly balance diaphragm. The force (2) due to downstream pressure acting on the top of the supply valve is in balance with the force (2) acting on the bottom of the balance diaphragm. The negative bias spring force acts upward against the bottom of the signal diaphragm.

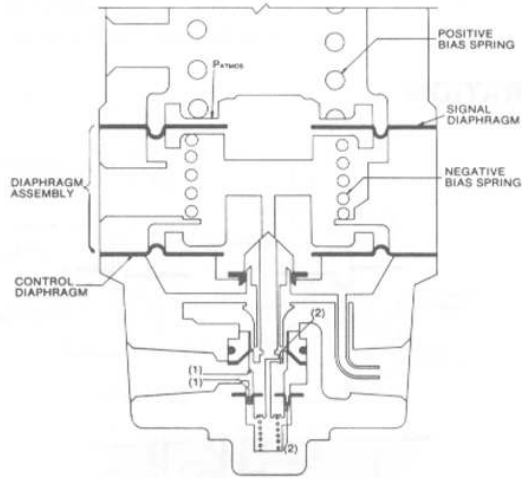

Figure 1B

As downstream pressure increases above setpoint, the increase in pressure will be transmitted through the aspirator tube to the bottom of the control diaphragm. The force on the bottom of the control diaphragm will cause the diaphragm assembly to move up, allowing the supply valve to be seated. As the diaphragm assembly and the relief seat continue to move up, sliding on the seal tube, the relief seat will move away from the relief valve, allowing downstream pressure to vent to chamber A. If this chamber is connected to the vacuum source, the force balance system will not be affected since upper and lower diaphragms are subjected to the same forces from the vacuum source.

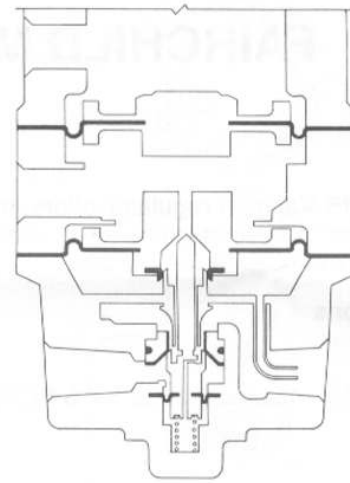
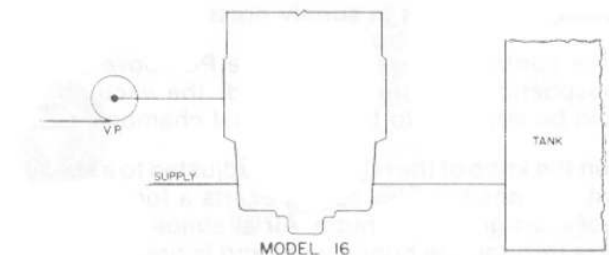
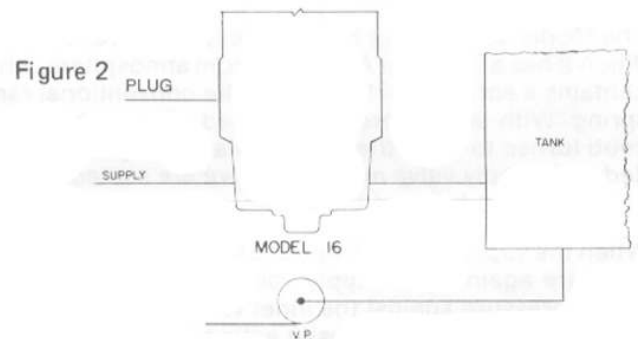

Figure 1C

Figures 2 and 3 show two methods of installing the Model 16 regulator. In applications requiring high frequency response of the system or for applications requiring fast evacuation of a vessel which is to be controlled below atmospheric level, the connection as shown in Figure 2 should be utilized. With this method the speed of evacuation and the frequency response of the system is directly dependent on the capacity of the vacuum pump and is not restricted by the relief capacity of the regulator.

In applications where control of system pressure may be required both above and below atmospheric pressure the method of connection shown in Figure 3 is recommended.



INSTALLATION

Clean pipe lines to remove dirt and scale before installation is made. Apply minimum amount of pipe compound to male threads of air line to avoid possibility of getting compound into regulator. Install regulator in air line; body is fitted with a 1/4" or 3/8" NPT for inlet and outlet connections. Regulator can be mounted in any position without affecting its operation. Inlet and outlet connections are labeled (look for arrows denoting direction of flow on underside of unit) and should be tightened securely. Avoid undersized fittings that will limit flow through the regulator and cause pressure drop downstream. The use of a filter to remove dirt and entrained liquid in the air line ahead of the regulator is recommended for best performance. If an air line lubricator is used, it should be located downstream beyond the regulator in order to avoid interference with the regulator performance.

NOTICE

The presence of certain diester oils in the airlines may hasten deterioration of the elastomers and thus decrease the useful life of this unit.

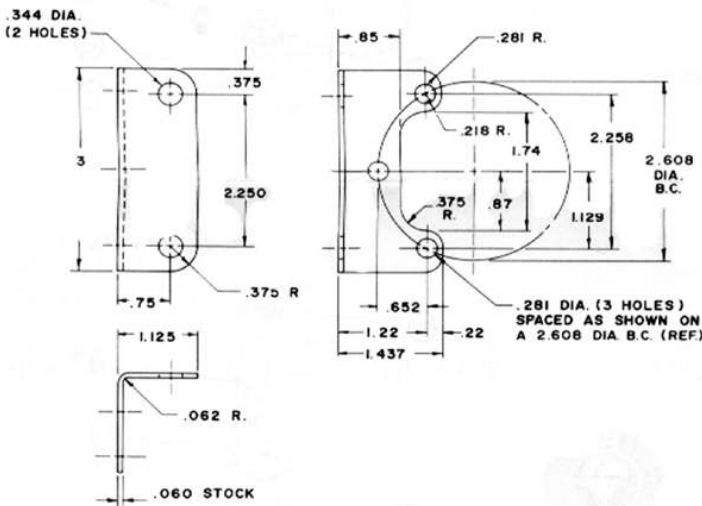
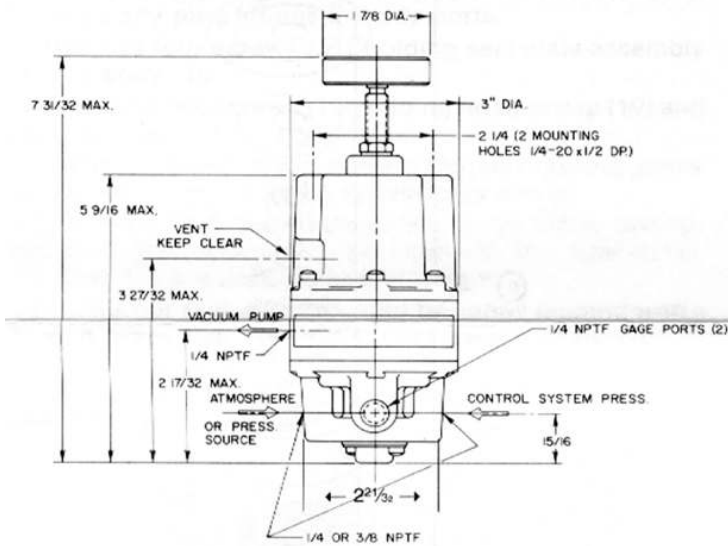

MOUNTING BRACKET EB-09921

ADJUSTMENTS

No field adjustments are necessary.

OPERATION

Relieve pressure on range spring before putting regulator into service for the first time. When operating at pressure above atmospheric, turn the adjusting screw slowly in a clockwise direction until required downstream pressure is obtained. For pressure below atmospheric, turn the

adjusting screw counterclockwise until the desired setting is obtained. Turned in a clockwise direction, the screw compresses the range spring causing increased output pressure. For decreased output pressure, or to set a lower vacuum setting, turn the screw counterclockwise.

MAINTENANCE

The regulator is easily disassembled for the occasional cleaning or removal of foreign matter. Before this is done, however, shut off valve upstream of the regulator to prevent escape of air when regulator is disassembled. Also shut off the controlled vacuum to avoid pressurizing the system. There is no need to remove the regulator from the pipe line; remove the two No. 10-32 screws on the bottom of the unit and pull out the inner valve assembly. Wash inner valve assembly with solvent exercising care

to avoid damaging diaphragms and valve facings. Replace assembly carefully. The vent hole in the bonnet should be kept clear. The adjusting screw should be lubricated with Molycote type "G" grease.

CAUTION

(Avoid such solvents as acetone, carbon tetrachloride, trichlorethylene)

TROUBLE SHOOTING

PROBLEM	CHECK
Leakage	Body screw tightness Diaphragm
High Bleed	Relief pintle and relief seat for damage or contamination
Difficult to Adjust	Adjusting screw and ball Seal ring lubrication

REPAIR PARTS LIST

Service Kit EA-12130 is available for maintenance of the regulator.

Service Kit EA-15744-1 is available for maintenance of the regulator with viton parts.

Service Kit EA-15744-2 is available for maintenance of the regulator with viton parts and L Option.

Service Kit EA-15747-1 is available for maintenance of the regulator with silicone parts.

Service Kit EA-15747-2 is available for maintenance of the regulator with silicone parts and L Option.

SERVICE KIT INSTALLATION

1. Check parts in the EA-12130 Service Kit against the parts marked with an asterisk in the exploded view and the associated table.
2. Examine the diaphragm assembly (9) for alignment between holes in both diaphragms and holes in the spacer ring (24). If the holes are not aligned, they can be brought into alignment by pressing on the end nut (21) or the relief seat assembly (28), while twisting slightly.
3. Loosen Lock nut (2)
4. Turn out knob assembly (1) to relieve tension on spring (5).
5. Remove six screws (6) in Bonnet.
6. Tap Bonnet Assembly (3) lightly with a rubber or rawhide mallet, and remove the bonnet assembly. Set aside spring seat (4) and spring (5).
7. Transfer nameplate from the old diaphragm assembly (9) to the kit diaphragm assembly.
8. Remove diaphragm assembly (9) from body (10). Remove any pipe fittings in body ports.
9. Remove four screws (11) holding seal plate assembly (13) to body (10).
10. Remove two screws (18) holding retainer cap (19) and retainer plate (17) to body (10).
11. Remove inner valve assembly (15) by pressing gently on the top of the inner valve assembly pintle.
12. Remove seal plate assembly (13) by lifting and rotating to free aspirator tube carefully and gasket(12). Caution: Do not damage end of tube.
13. Drive out seat assembly (29) by lightly tapping with a 3/8 inch brass rod. The rod should have a chamfered or rounded end.
14. Clean the body (10) with a suitable solvent and blow dry with compressed air.
15. Secure seat assembly (29) from the kit and insert from bottom end of the body (10). Make sure that the valve seat is facing bottom of the regulator. Insert shoulder end first. Tap lightly to seat the assembly.
16. Secure gasket (12) from the kit and place in the seal chamber, aligning gasket holes with the tapped holes in the body.
17. Insert seal plate assembly (13) by rotating carefully so that the aspirator tube is facing the port on the body (10) marked OUT.
18. Using four screws (11), fasten seal plate assembly (13) and gasket (12) to body (10).
19. Secure inner valve assembly (15) from kit and insert from bottom end of body (10). Tap lightly to seat the assembly. NOTE: Make sure that the screen is seated in the groove of the inner valve assembly.
20. Place retainer plate (17) and cap (19) over the inner valve assembly (15) and secure with two screws (18).
21. Place diaphragm assembly (9) on body (10) with port stamped V over the port marked IN. Place spring (5) on diaphragm assembly (9) and place spring seat (4) over spring (5).
22. Position bonnet assembly (3) over diaphragm assembly (9) so that the vent port is directly over the port marked V on the diaphragm assembly (9) and the screw holes are aligned. Lubricate six screws (6) with silicone and insert through bonnet assembly (3), diaphragm assembly (9) to body (10). Alternately tighten opposite screws to guard against warping the bonnet assembly.
23. Lubricate knob assembly screw (1) with Molycote.
24. Reinstall the regulator in accord with installation instructions in the IOM and follow instructions in the operation section for placing the regulator back into service.

OPTION TABLE

	STD	T	J	1/4 NPT	3/8 NPT	A	U	H
Knob Assy.	EB-4124-1	EA-1129 Nut EB-7057-2 (Cap Nut)						
Diaphragm Assy.	EB-8899-16		EB-12649-4			EB-16548-5		
Inner Valve Assy.	EC-1820		EB-11948	EC-11951-1	EC-11951-2	EB-11947		
Molded Seat	ED-6070					EB-8161		
Body & Valve Assy.							EC-1821-()	EC-1821-()
	AL	JL	L					
Diaphragm Assy.	EB-16548-7	EB-12649-6	EB-8899-19					

Index	Part No.	Description
1	EB-4124	Knob Assembly
2	EA-1120	Locknut
3	EB-1823-1	Bonnet Assembly
4	EB-6058	Spring Seat
5	EC-6060-()	Spring
6	EA-1032-32	Screw
* 9	EB-8899-16	Diaphragm Assembly
10	EB-6050-()	Body
11	EA-1032-5	Screw
*12	EB-6053	Gasket
13	EB-1948	Seal Plate Assembly
*15	EB-1820	Inner Valve Assembly
17	EA-6027	Retainer Plate
18	EA-1032-6	Screw
19	EB-7136	Retainer Cap
*29	EB-6070	Seat Assembly

*EA-12130 Kit Components

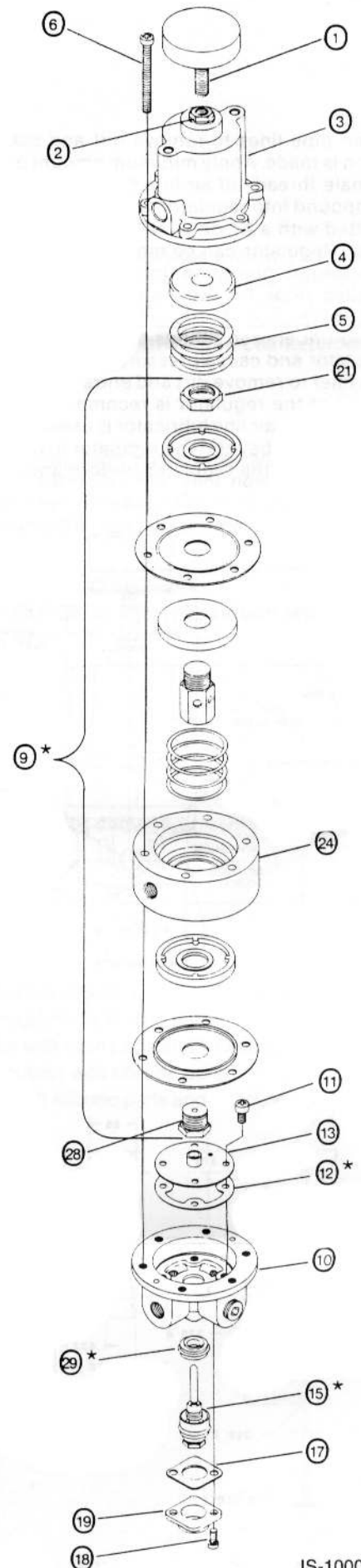

Legal Notice

The information set forth in the foregoing Installation, Operation and Maintenance Instructions shall not be modified or amended in any respect without prior written consent of Fairchild Industrial Products Company. In addition, the information set forth herein shall be furnished with each product sold incorporating Fairchild's unit as a component thereof.



3920 WEST POINT BLVD. WINSTON-SALEM, NC 27103-6708
 TEL 336-659-3400 FAX 336-659-9323

www.fairchildproducts.com



ISO 9001:2000
 FM NO. 25571

IS-1000016
 Litho in USA
 Rev. J 1/04